



Special Features

- Individual freefloating load cushions held in place by outside steel collar.
- Completely machined castings.
- Easy to assemble & disassemble.
- Cushions easily inspected at all times.

Applications

For pumps in chemical industry, ideal for reciprocating pumps, diesel or gas engines, multiple generator sets and such heavy duty applications.

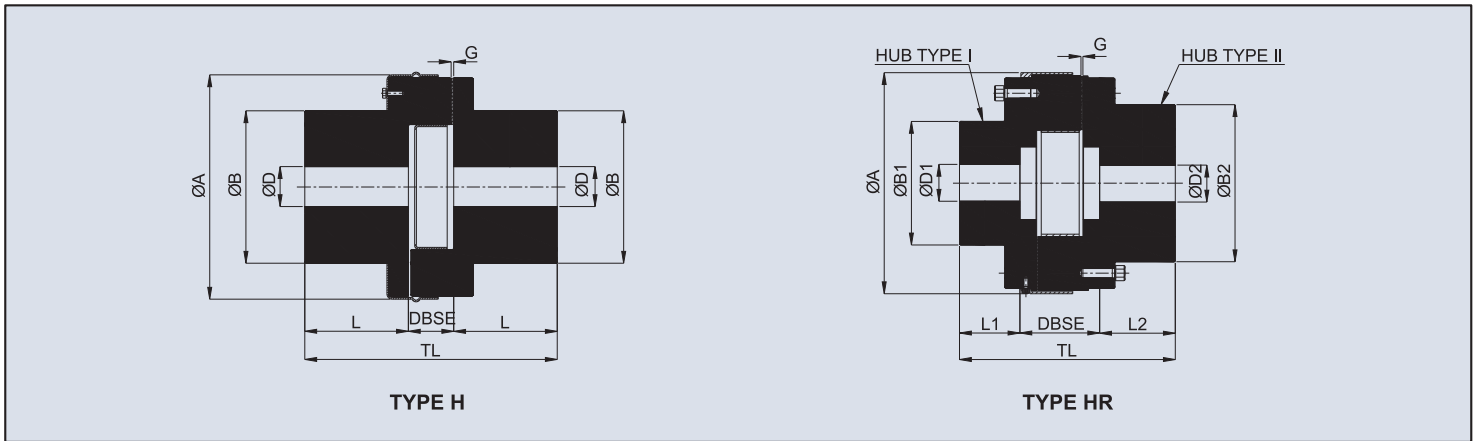

'H' TECHNICAL DATA

Size	kW at 100 rpm			Gap G	Bore (ØD)		Outside Dia. ØA	Hub Dia. ØB	Length thru' Bore L	DBSE	Overall Length TL	Approx. weight in kg	
	Synthetic Rubber	Polyurethane	HTrans		Min.	Max.						Min. Bore	Max. Bore
H-307	56	84	140	3	60	105	262	180	121	53	295	58	55
H-357	75	112	187	3	60	115	288	197	127	60	314	73	67
H-367	104	156	260	3	70	130	313	222	143	67	353	105	99

'HR' TECHNICAL DATA

Size	KW at 100 rpm			Gap G	Type I Bore (ØD1)	Type II Bore (ØD2)		Outside Dia. ØA	Hub Dia. ØB	Length thru' Bore L	DBSE	Overall Length TL			
	Synthetic Rubber	Polyurethane	HTrans			Min.	Max.					Min. Bore	Max. Bore		
HR-307	56	84	140	3	30	80	60	105	266	131	170	68	85	100	253
HR-357	75	112	187	3	35	85	60	115	292	138	180	76	95	110	281
HR-367	104	156	260	3	40	100	70	130	317	162	210	84	105	117	306
HR-407	-	223	372	3	50	120	85	155	349	195	248	95	120	126	341
HR-457	-	302	502	3	60	140	85	185	400	220	294	100	130	134	364
HR-507	-	358	597	6	70	145	90	190	412	230	305	110	140	133	383
HR-557	-	527	877	6	85	170	100	225	461	275	360	130	170	142	442
HR-607	-	738	1230	6	90	190	100	265	524	300	425	140	195	162	497
HR-657	-	-	1530	6	100	215	120	295	592	345	470	155	210	196	561
HR-707	-	-	1770	6	100	265	170	340	661	420	545	190	240	216	646

- All dimensions are in mm.
- Maintain Gap 'G' = 3mm for size HR-307 TO HR-457 & 6mm For higher sizes at the time of assembly.
- Please specify hub type required.
- Non std. DBSE spacer available on request.
- For vertical installation contact us

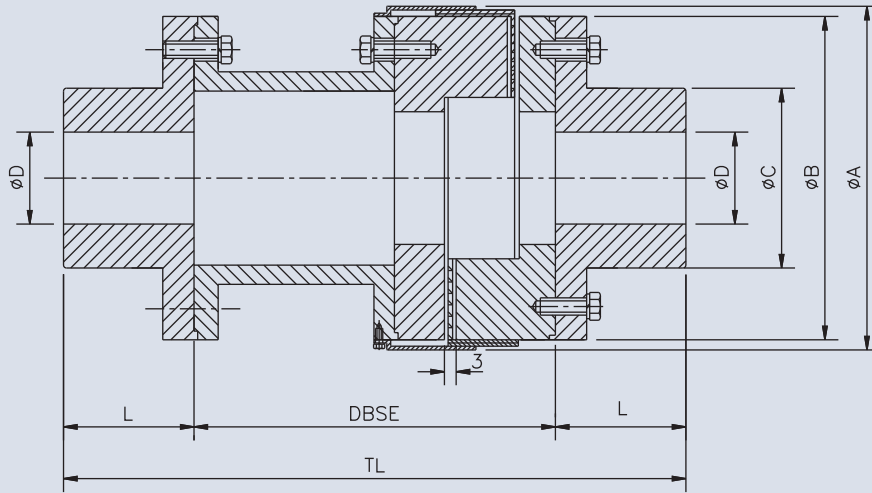

SWS TECHNICAL DATA

Size	Coupling Rating						Bore ϕD		Dimensions (mm)					
	Synthetic Rubber		Polyurethane		HTrans				ϕA	ϕB	ϕC	L	Min. DBSE	TL
	Torque Nm	kW at 100 RPM	Torque Nm	kW at 100 RPM	Torque Nm	kW at 100 RPM	Min.	Max.						
SWS-276	532	5.6	798	8.4	1330	13.9	25	75	173	154	130	60	180	300
SWS-280	782	8.2	1173	12.3	1955	20.5	30	80	208	189	130	65		300
SWS-295	1279	13.4	1919	20.1	3198	33.5	30	95	253	234	160	80		320
SWS-2955	2132	22.3	3198	33.5	5330	55.8	30	105	253	234	160	80		330
SWS-300	3047	31.9	4571	47.9	7618	79.8	30	105	272	251	180	88	215	375
SWS-350	4308	45.1	6462	67.7	10770	112.8	30	115	323	302	200	90		395

- Pilot bores other than specified are available on request.
- Non std. spacer length available on request.
- For vertical installation contact us.

In view of our constant endeavour to improve quality of our products, we reserve the right to alter or change specifications without prior notice.



NVT india[®]
Plot No. 6 & 7, Survey No. 17, Paras Ind.
Estate, N.H. 27, Bharudi - 360 311, Ta. Gondal,
Dist. Rajkot(GUJ) India
Ph : 02825-280685/86/87
sales@nvtindia.com, www.nvtindia.com

Distributor